

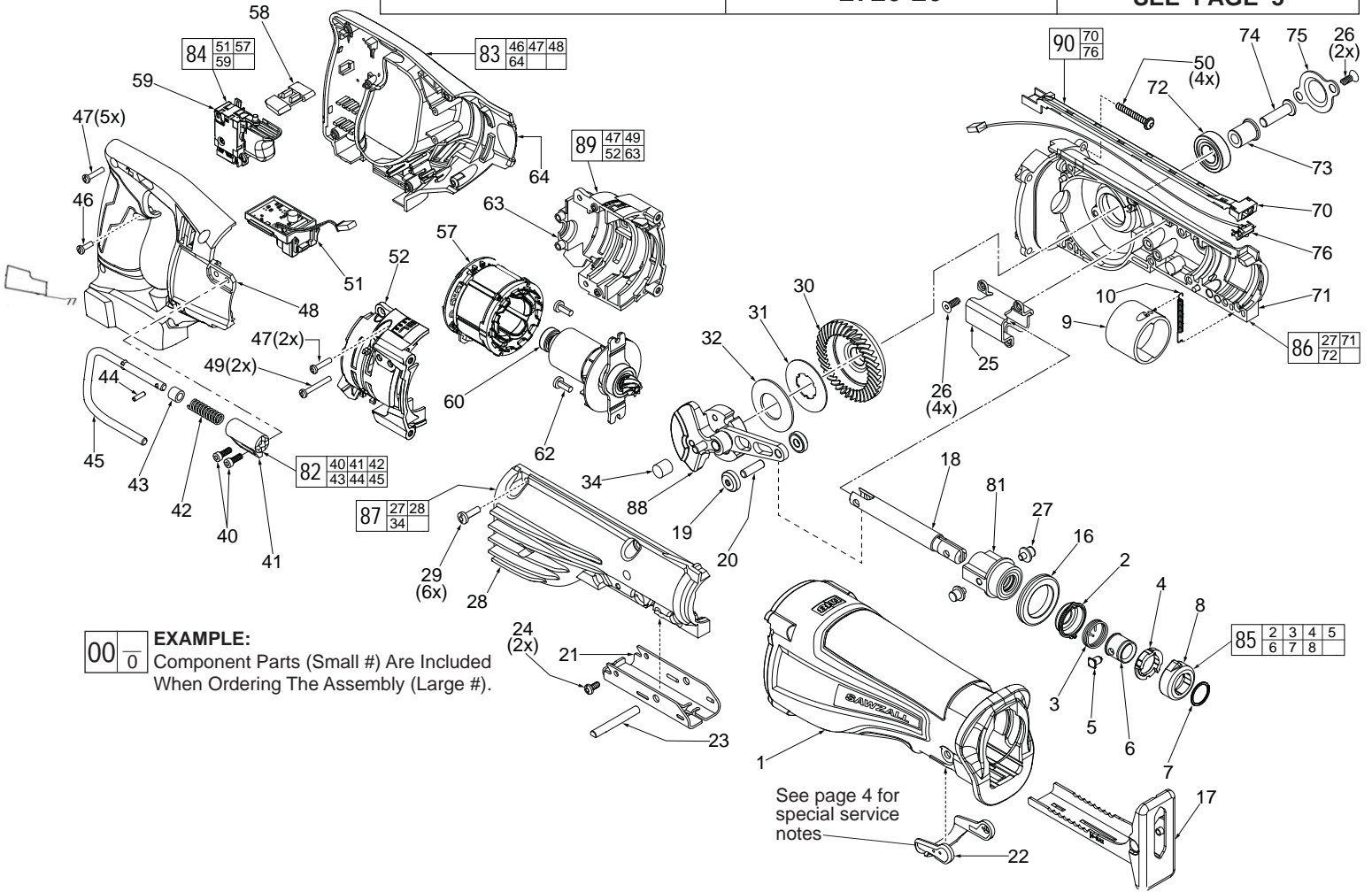

# SERVICE PARTS LIST

SPECIFY CATALOG NO. AND SERIAL NO. WHEN ORDERING PARTS		DATE Aug. 2015
<b>M18 FUEL™ SAWZALL® Reciprocating Saw</b>		WIRING INSTRUCTION <b>SEE PAGE 5</b>
MODEL NO. M18CSX-0	2720-20	



**EXAMPLE:**  

00	0
----	---

 Component Parts (Small #) Are Included  
 When Ordering The Assembly (Large #).

See page 4 for  
 special service  
 notes

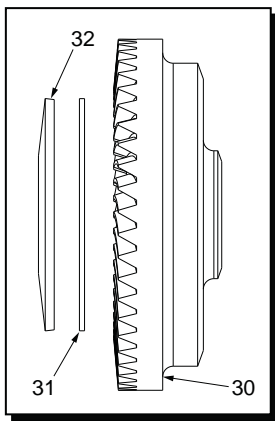
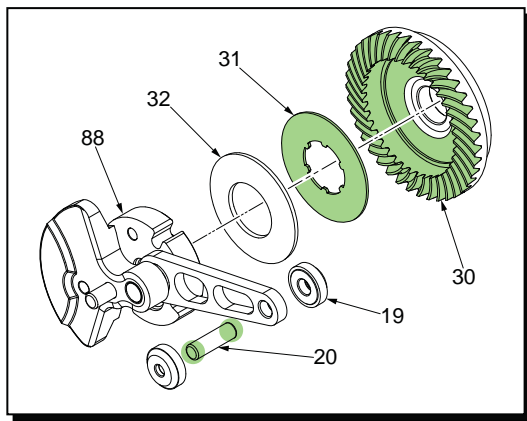

Concave side of disc spring (32) must face toward metal plate (31) and bevel gear (30).

When securing the orbit slot (25), tighten screws (26) in the order shown.

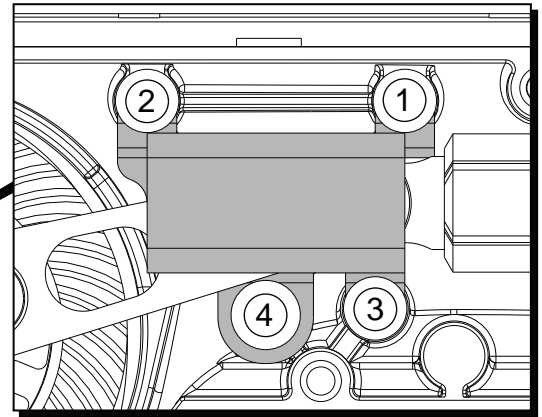

Pinion Gear of Rotor Assembly #80

**NOTE:** Counter Weight of Crankshaft Assembly #88 has been removed for clarity (to reveal pinion gear)

**NOTE:** Orbit Slot #25 has been removed from this view for clarity (to reveal Connecting Rod Pin #20 and Rollers #19)

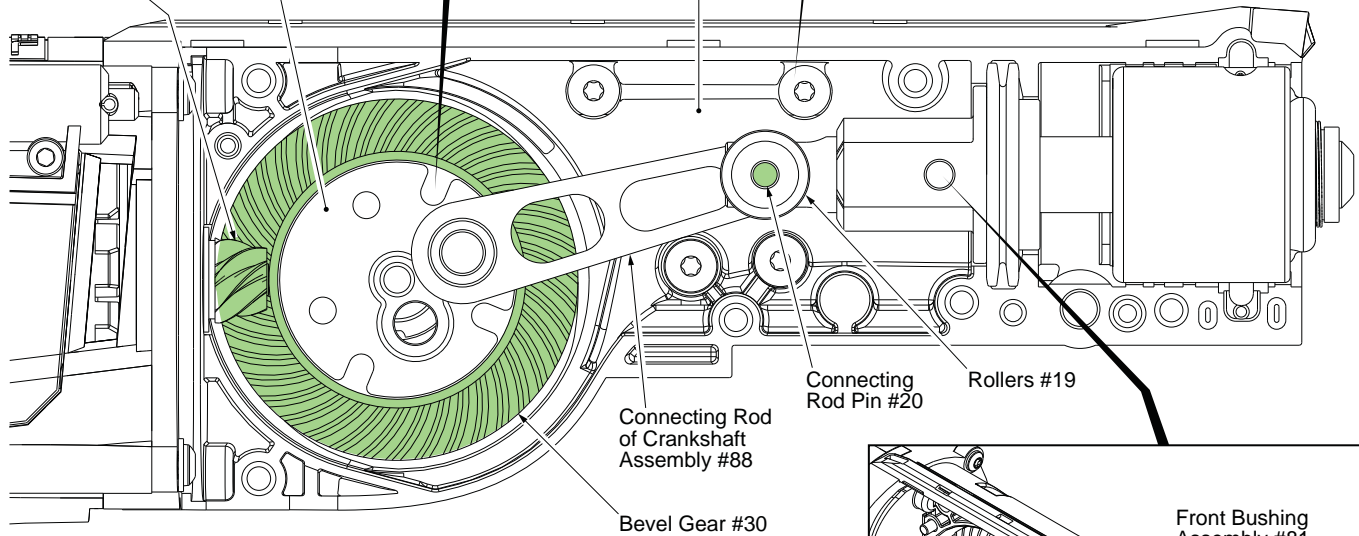

Connecting Rod Pin #20  
Rollers #19

Connecting Rod of Crankshaft Assembly #88  
Bevel Gear #30

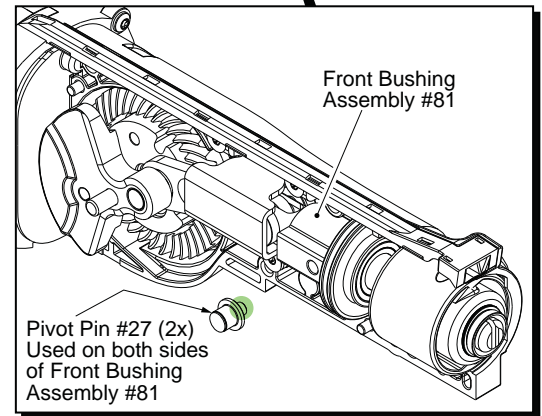

Front Bushing Assembly #81

Pivot Pin #27 (2x)  
Used on both sides of Front Bushing Assembly #81

**LUBRICATION: Type 'L' Grease**  
**No. 49-08-4175 (16 oz. tub)**

- Place 30g ±3g (approx. 1 ounce) on top of gear (30) and pinion gear of rotor assembly (80), being sure to cover the middle of the gear and all teeth.
- Place 15g ±3g (approx. .5 ounce) to the area where the gear (30) and the connecting rod of crank shaft assembly (88) interface.
- Coat both sides of the metal clutch plate (31).
- Lightly coat both pivot pins (27) where connections go into holes of front bushing assembly (81).
- Lightly coat both ends of pin (20) prior to installing rollers (19).

**BACK VIEW**

Ball bearing (3) to be pressed to gearcase stop with seal to the outside.

Press needle bearing (5) flush to subflush .005".

Retaining Plate (75)

Seal

Gearcase stop

Approximately .020-.025 above gearcase bore

Ball bearing (72)



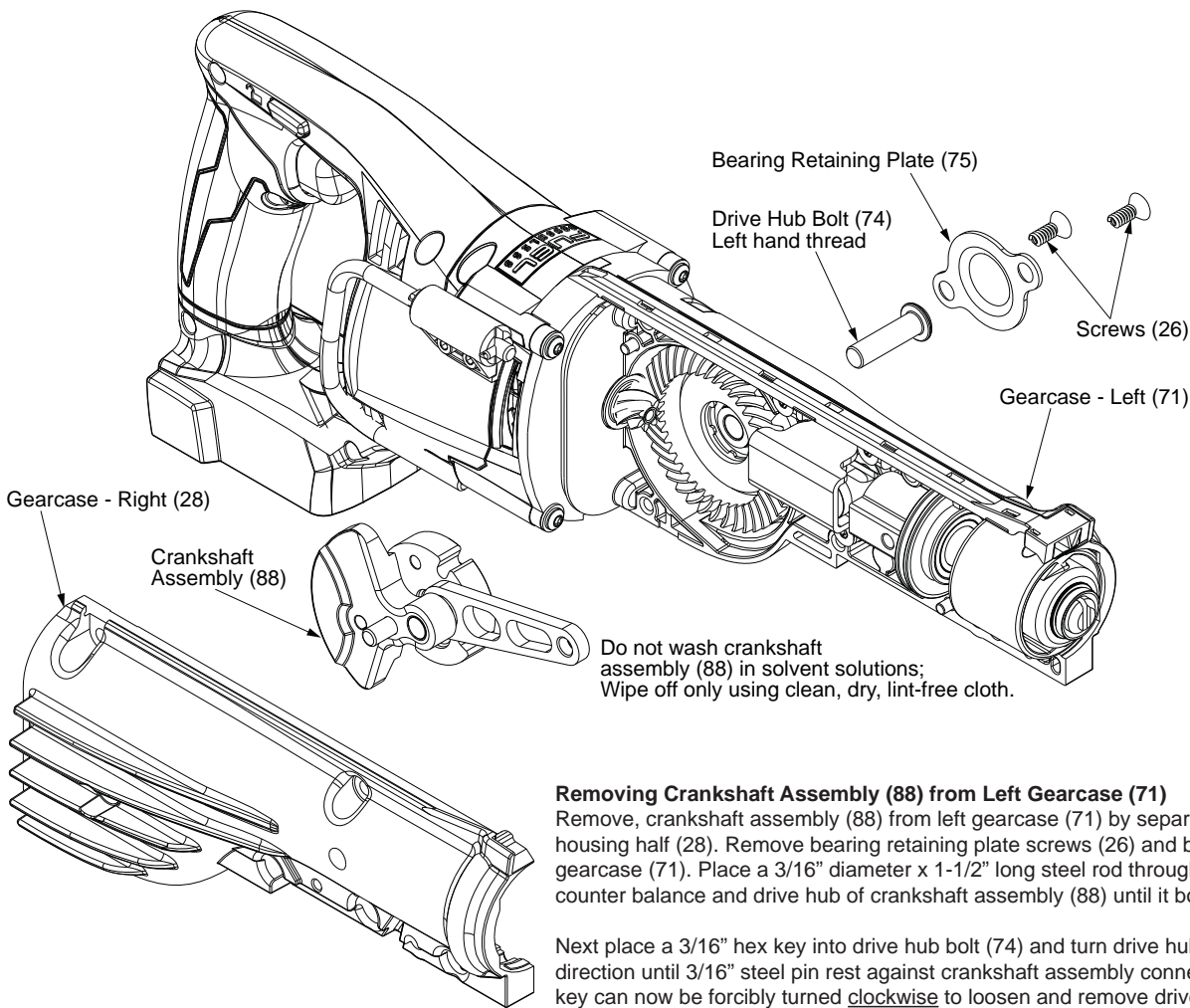

**Removing Crankshaft Assembly (88) from Left Gearcase (71)**

Remove, crankshaft assembly (88) from left gearcase (71) by separating / removing right housing half (28). Remove bearing retaining plate screws (26) and bearing plate (75) from left gearcase (71). Place a 3/16" diameter x 1-1/2" long steel rod through the holes found in the counter balance and drive hub of crankshaft assembly (88) until it bottoms out.

Next place a 3/16" hex key into drive hub bolt (74) and turn drive hub bolt slowly in a clockwise direction until 3/16" steel pin rest against crankshaft assembly connecting rod. The 3/16" hex key can now be forcibly turned clockwise to loosen and remove drive hub bolt (74).

**Reinstalling Crankshaft Assembly (88) into Left Gearcase (71)**

To reinstall drive hub bolt (74) to crankshaft assembly (88) apply Blue Loctite® to threads of drive hub bolt (74) and insert through spacer (73) aligning threads of drive hub bolt (74) with internal threads of crankshaft assembly hub. Use a 3/16" hex key to turn the drive hub bolt (74) slowly in a counter clockwise direction until 3/16" steel pin rest against crankshaft assembly connecting rod (See 'Removing Crankshaft Assembly' instructions above). Using an inch pound torque wrench and a 3/16" hex key, torque drive hub bolt (74) to 210-240 in. lbs. or bolt can be tightened using a ft. lbs. torque wrench to 17-20 ft. lbs.

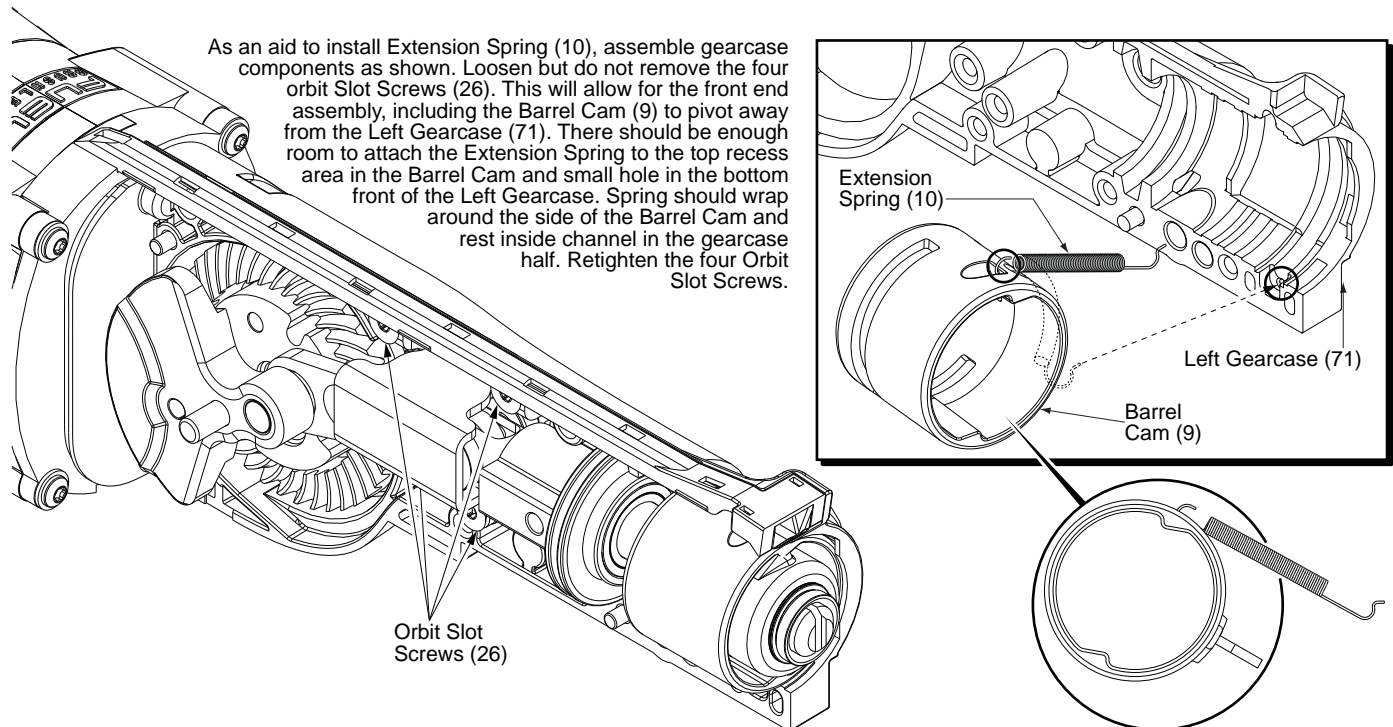

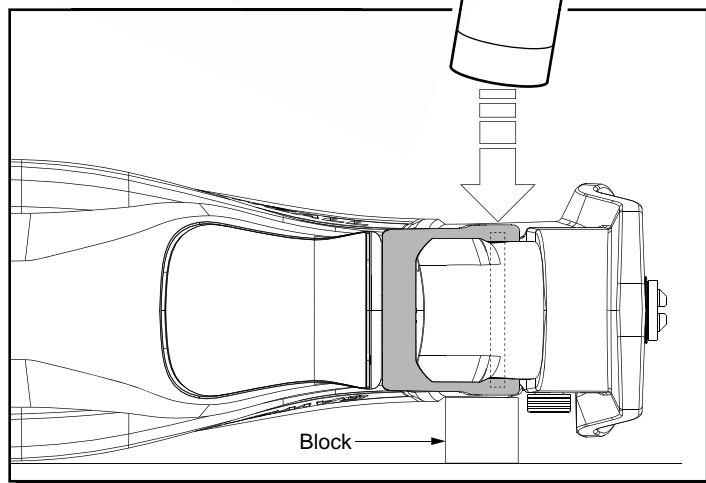
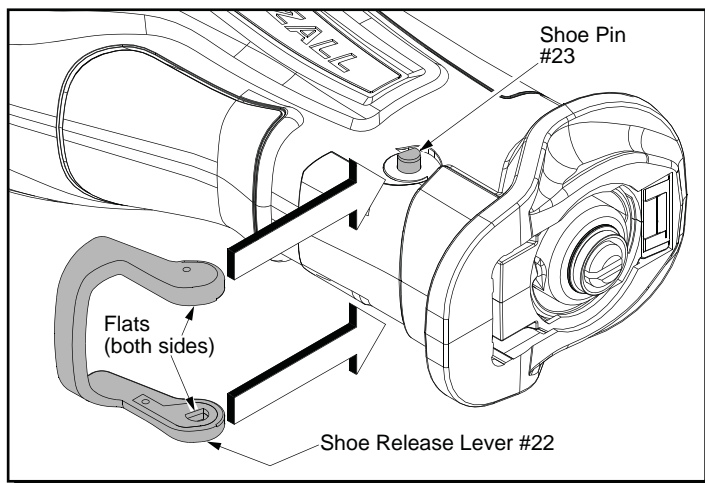

**To properly install the Shoe Release Lever #22 onto the Shoe Pin #23 do the following:**

Insert the shoe pin through the hole in the gearcase insulator. Center the shoe pin with equal amounts of the pin protruding from each side of the tool.

Rotate the shoe pin so the flats of the pin will align with the flats in the shoe release lever cavities.

The shoe release lever is stiff but flexible. Place the shoe release lever over the gearcase insulator. Lift one end of the shoe release lever onto the shoe pin (with flats aligned) and press into place.

Pull the other end of the shoe release lever over the other side of the pin and press in place.

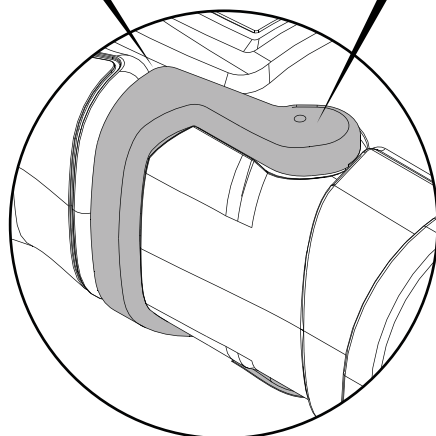

Place the tool on its side on a hard flat surface. Place a small wood block approximately 1-1/8" thick under the tool, between the hard surface and the shoe release lever, directly beneath the pin.

With a rubber mallet, strike the shoe release lever several times to completely seat the lever onto the pin and to assure that the pin is properly centered within the gearcase.

**REMOVING THE STEEL QUIK-LOK® BLADE CLAMP -**

- Remove external retaining ring (7) and pull front cam (8) off.
- Pull lock pin (5) out and remove remainder of parts and discard.

**REASSEMBLY OF THE STEEL QUIK-LOK® BLADE CLAMP**

- Coat new lock pin with powdered graphite.
- Hold tool in a vertical position.
- Place spring cover onto spindle.
- Slide torsion spring (3) onto spindle with spring leg on hole side of spindle.
- Slide sleeve (6) onto spindle aligning hole on sleeve with hole in spindle.
- Slide rear cam over sleeve until it bottoms on sleeve shoulder, ensure spring leg inserts into groove of cam.
- Rotate rear cam in the direction of the arrows located on spring cover until there is clearance for lock pin (5) to be inserted into sleeve/spindle holes. Insert lock pin.
- Align front cam (8) inner ribs with rear cam outer slots and slide front cam onto sleeve until it bottoms. Retaining ring groove should be completely visible.
- Attach retaining ring (7) by separating coils and inserting end of ring into groove, then wind remainder of ring into groove. Ensure ring is seated in groove.
- Blade clamp should rotate freely. During normal usage, debris may not allow blade clamp to rotate freely. The use of spray lubricant can help free blade clamp. In extreme conditions, follow these instructions to remove, clean and reassemble blade clamp.

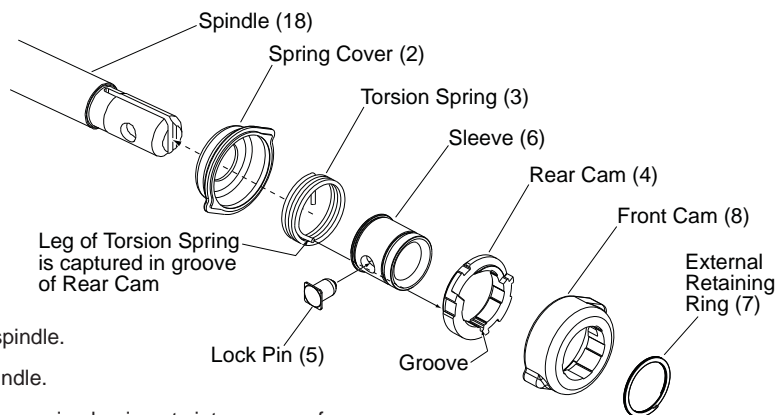

Prior to installing the LED and Tray Assembly #90, route High Voltage Wire #92 around and through the Motor Cage Assembly #89 as shown. Secure to the Gearcase Half #28 with Screw #29.

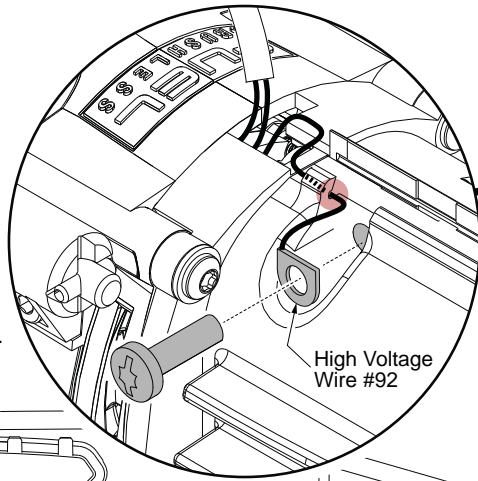

High Voltage Wire #92

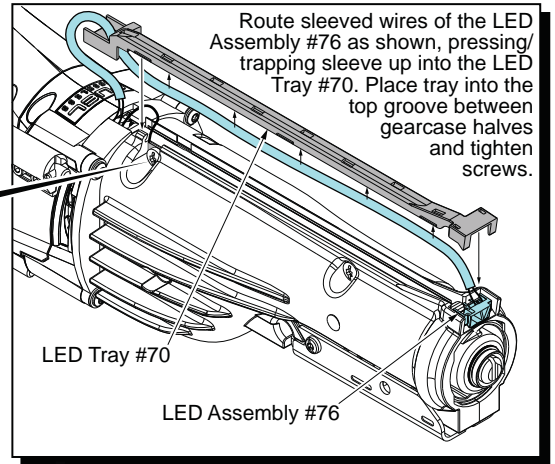

Route sleeved wires of the LED Assembly #76 as shown, pressing/trapping sleeve up into the LED Tray #70. Place tray into the top groove between gearcase halves and tighten screws.

LED Tray #70

LED Assembly #76

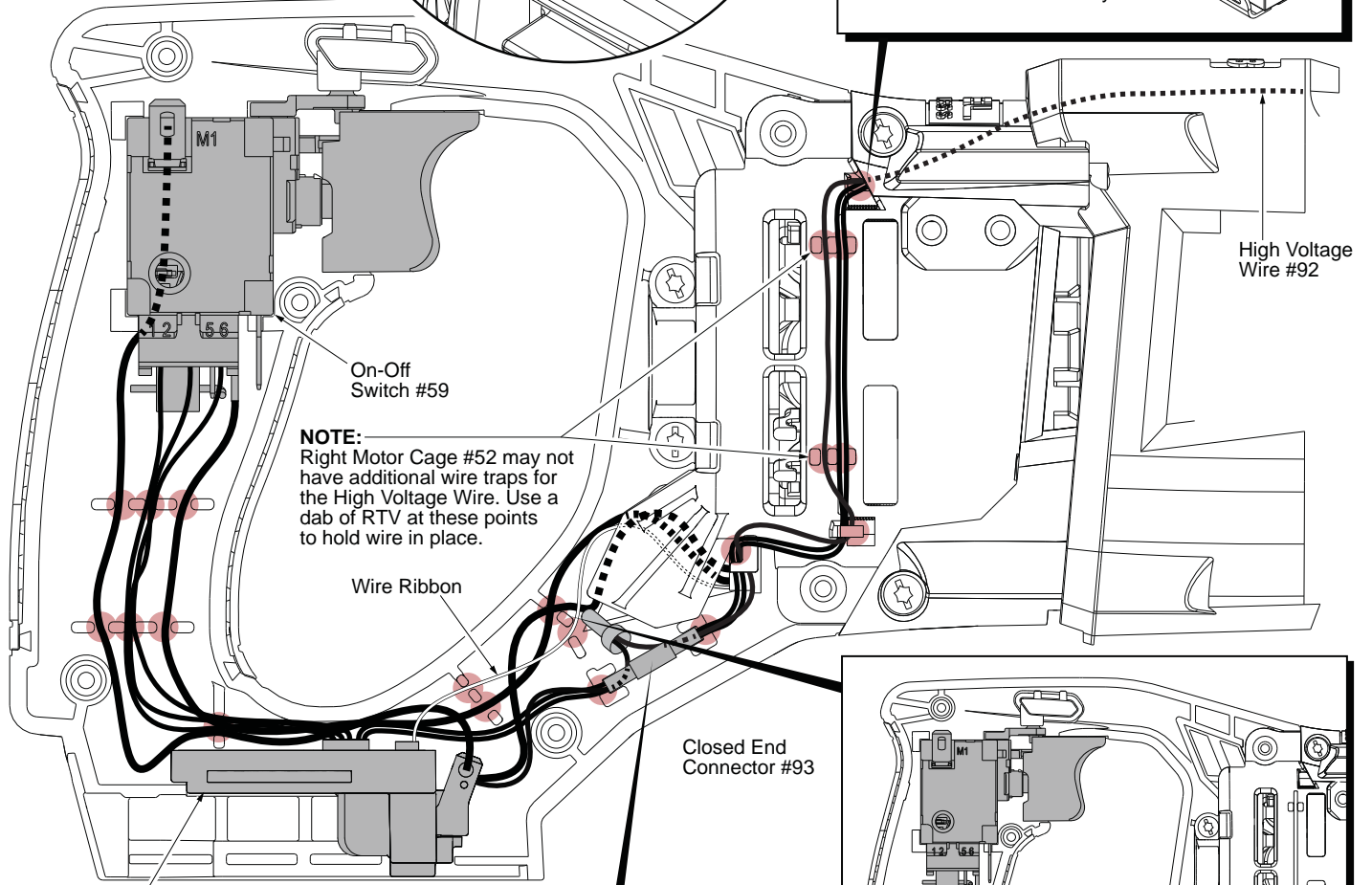

**NOTE:**  
Right Motor Cage #52 may not have additional wire traps for the High Voltage Wire. Use a dab of RTV at these points to hold wire in place.

Wire Ribbon

Closed End Connector #93

High Voltage Wire #92

Control Board/Terminal Connector Block #51

● = WIRE TRAPS or GUIDES

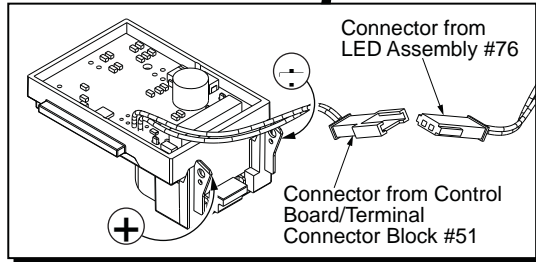

Connector from LED Assembly #76

Connector from Control Board/Terminal Connector Block #51

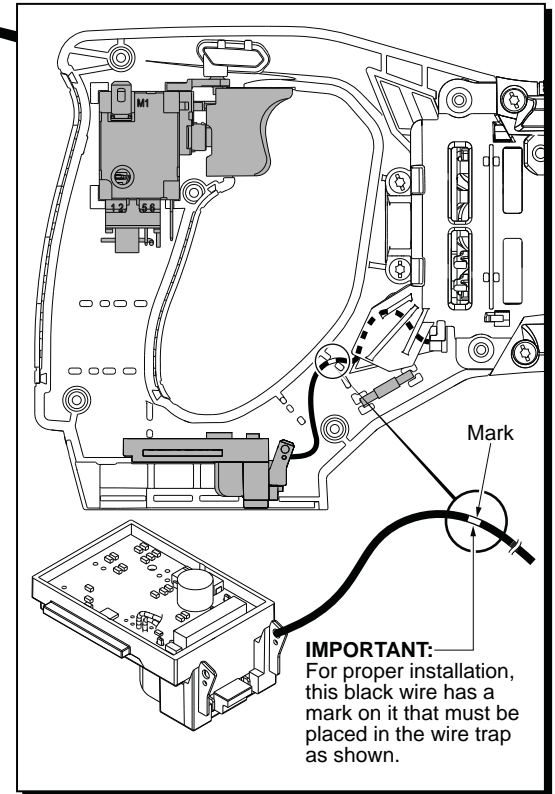

Mark

**IMPORTANT:**  
For proper installation, this black wire has a mark on it that must be placed in the wire trap as shown.

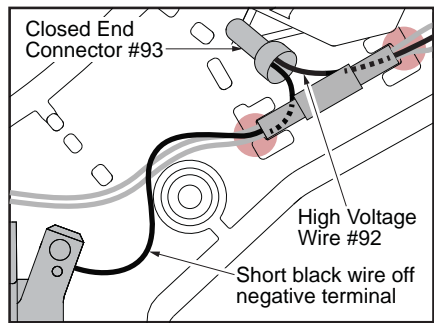

Closed End Connector #93

High Voltage Wire #92

Short black wire off negative terminal

Strip short black wire (from the negative terminal of the Control Board/Terminal Connector Block #51) to about 3/16". Strip High Voltage Wire #92 to approximately 3/16". Twist the metal strands of both wires together. Twist a Closed End Connector #93 over the wire strands. Crimp the barrel of the connector to secure the wires. Route the High Voltage Wire as shown above starting with the HV wire in the bottom of the LED/Terminal connector cavity, under the joined connectors.